

深圳市色彩光电有限公司

**Shenzhen LED Color Opto Electronic Co.,ltd**

Factory Address 1:5th floor Dadong Ming Science and Technology Park Yuequn road Changzhen Viliage Guangming New

District Shenzhen

Factory Address 2:2th floor Changxing Technology Industrial Park Chanzhen Viliage Guangming New District Shenzhen

Tel:+86-0755-27350605

Fax:+86-0755-2324-5913

# LC8812B-RGBX-XX

## SPECIFICATION

### INTEGRATED LIGHT SOURCE INTELLIGENT CONTROL OF CHIP-ON-TOP SMD TYPE LED

Document No.: SPC/ LC8812B-RGBX-XX

Model No.: LC8812B-RGBX-XX

Description: 5.5x5.0x1.6mm Top SMD Type 0.25 Watt Power  
tegrated light source Intelligent control LED



INTEGRATED LIGHT SOURCE INTELLIGENT CONTROL  
OF CHIP-ON-TOP SMD TYPE LED

**Model: LC8812B-RGBX-XX**

**1. Product Overview :**

LC8812B-RGBX-XX is a smart LED control circuit and light emitting circuit in one controlled LED source, which has the shape of a 5050 LED chip. Each lighting element is a pixel, and the intensities of the pixels are contained within the intelligent digital interface input. The output is driven by patented PWM technology, which effectively guarantees high consistency of the color of the pixels. The control circuit consists of a signal shaping amplification circuit, a built-in constant current circuit, and a high precision RC oscillator.

The data protocol being used is unipolar NRZ communication mode. The 32-bit data is transmitted from the controller to DIN of the first element, and if it is accepted it is extracted pixel to pixel. After an internal data latch, the remaining data is passed through the internal amplification circuit and sent out on the DO port to the remaining pixels. The pixel is reset after the end of DIN. Using automatic shaping forwarding technology makes the number of cascaded pixels without signal transmission only limited by signal transmission speed.

The LED has a low driving voltage (which allows for environmental protection and energy saving), high brightness, scattering angle, good consistency, low power, and long life. The control circuit is integrated in the LED above.

**2. Main Application Field:**

- Full color LED string light, LED full color module, LED super hard and soft lights, LED guardrail tube, LED appearance / scene lighting
- LED point light, LED pixel screen, LED shaped screen, a variety of electronic products, electrical equipment etc..

**3. Description:**

- Top SMD internal integrated high quality external control line serial cascade constant current IC;
- control circuit and the chip in SMD 5050 components, to form a complete control of pixel, color mixing uniformity and consistency;
- built-in data shaping circuit, a pixel signal is received after wave shaping and output waveform distortion will not guarantee a line;
- The built-in power on reset and reset circuit, the power does not work;
- gray level adjusting circuit (256 level gray scale adjustable);
- red drive special treatment, color balance;
- line data transmission;
- plastic forward strengthening technology, the transmission distance between two points over 10M;
- Using a typical data transmission frequency of 800 Kbps, when the refresh rate of 30 frames per sec

**4. Mechanical Dimensions:**

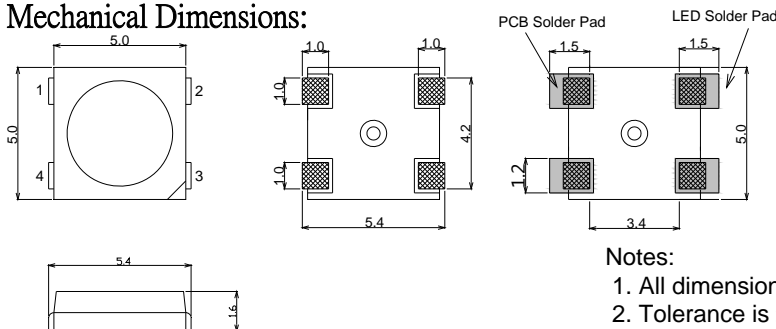

### 5. PIN configuration

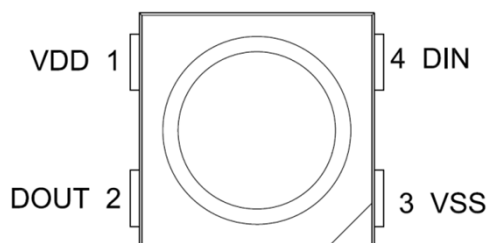

NO.	Symbol	Function description
1	VDD	Power supply LED
2	DOUT	Control data signal output
3	VSS	Ground
4	DIN	Control data signal input

### 6. General Information

# LC8812B-RGBW/Y-XX

The default is the chips with IC integration

R: RED 620-630NM  
G: GREEN 515-530 NM  
B: BLUE 460-470 NM  
X: White Color Or Yellow  
Y: Yellow 585-595 NM  
W : White Color  
-xx BW Blue White 6000-7000K  
NW Natural White 3800-4500K  
WS Warm Sunlight 2700-3200K

**7. Absolute Maximum Ratings (Ta=25°C, VSS=0V) :**

Parameter	Symbol	Range	Unit
Power supply voltage	VDD	+3.5~+5.5	V
Logic input voltage	V <sub>IN</sub>	-0.5~VDD+0.5	V
Working temperature	T <sub>opt</sub>	-40~+85	°C
Storage temperature	T <sub>stg</sub>	-50~+150	°C
ESD pressure	V <sub>ESD</sub>	4K	V

**8. The electrical parameters (unless otherwise specified, TA=-20 ~ +70 °C, VDD=4.5 ~ 5.5V, VSS=0V):**

Parameter	Symbol	Min	Typical	Max	Unit	Test conditions
The chip supply voltage	VDD	---	5.2	---	V	---
R/G/B port pressure	VDS,MAX	---	---	26	V	---
DOUT drive capability	IDOH	---	49	---	mA	DOUT connect ground, the maximum drive current
	IDOL	---	-50	---	mA	DOUT connect +, the largest current
The signal input flip threshold	VIH	3.4	---	---	V	VDD=5.0V
	VIL	---	---	1.6	V	
The frequency of PWM	FPWM	---	1.2	---	KHZ	---
Static power consumption	IDD	---	1	---	mA	---

**9. The dynamic parameters (Ta=25 °C):**

Parameter	Symbol	Min	Typical	Max	Unit	Test conditions
The speed of data transmission	fDIN	---	800	---	KHZ	The duty ratio of 67% (data 1)
DOUT transmission delay	TPLH	---	---	500	ns	DIN→DOUT
	TPHL	---	---	500	ns	
IOUT Rise/Drop Time	Tr	---	---	40	ns	VDS=1.5 IOUT=9mA
	Tf	---	---	80	ns	

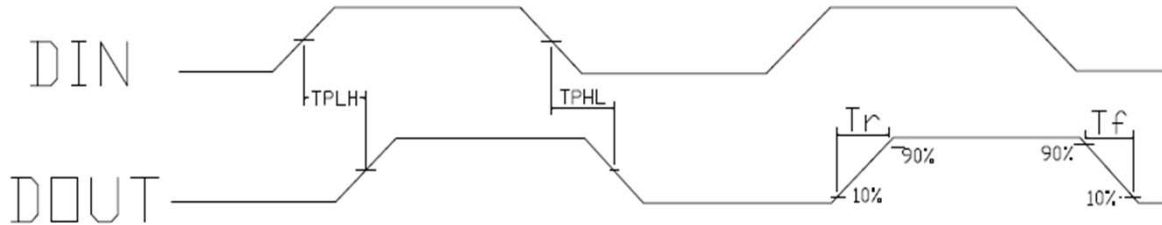

**10. The data transmission time ( $T_H+T_L=1.25\mu s \pm 600ns$ ):**

T0H	0 code, high level time	0.3 $\mu s$	$\pm 0.15\mu s$
T0L	0 code, low level time	0.9 $\mu s$	$\pm 0.15\mu s$
T1H	1 code, high level time	0.6 $\mu s$	$\pm 0.15\mu s$
T1L	1 code, low level time	0.6 $\mu s$	$\pm 0.15\mu s$
Trst	Reset code, low level time	80 $\mu s$	

**11. Timing waveform:**

Input code:



Connection mode:

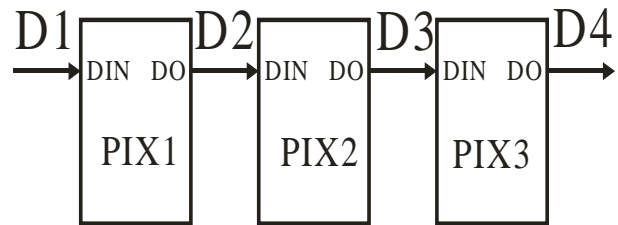

**12. The method of data transmission:**

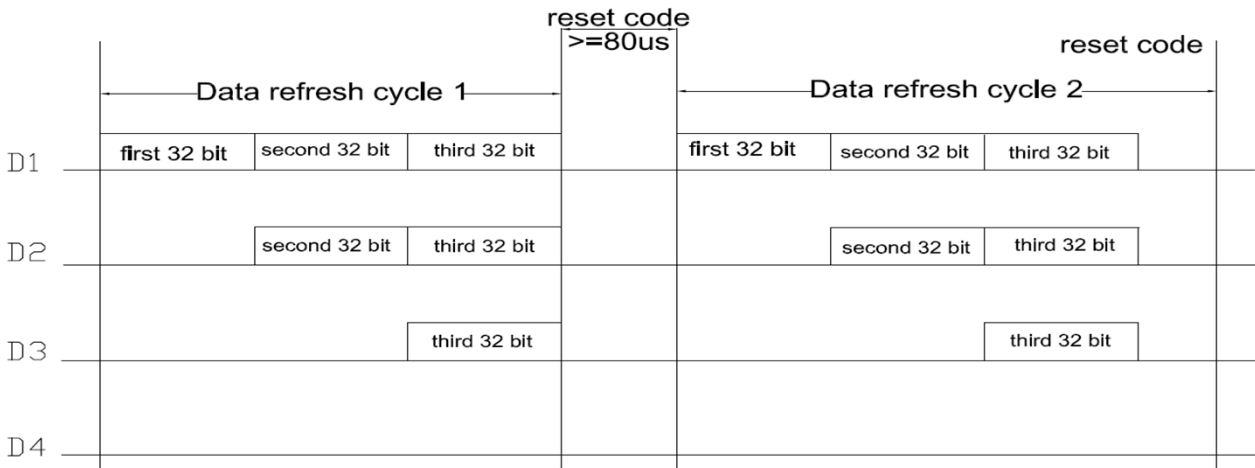

Note: the D1 sends data for MCU, D2, D3, D4 for data forwarding automatic shaping cascade circuit.

13. The data structure of 32bit:

G7	G6	G5	G4	G3	G2	G1	G0	R7	R6	R5	R4
R3	R2	R1	R0	B7	B6	B5	B4	B3	B2	B1	B0
W7	W6	W5	W4	W3	W2	W1	W0				

Note: high starting, in order to send data (R7 - R6 - ..... ..W0)

14. The typical application circuit:

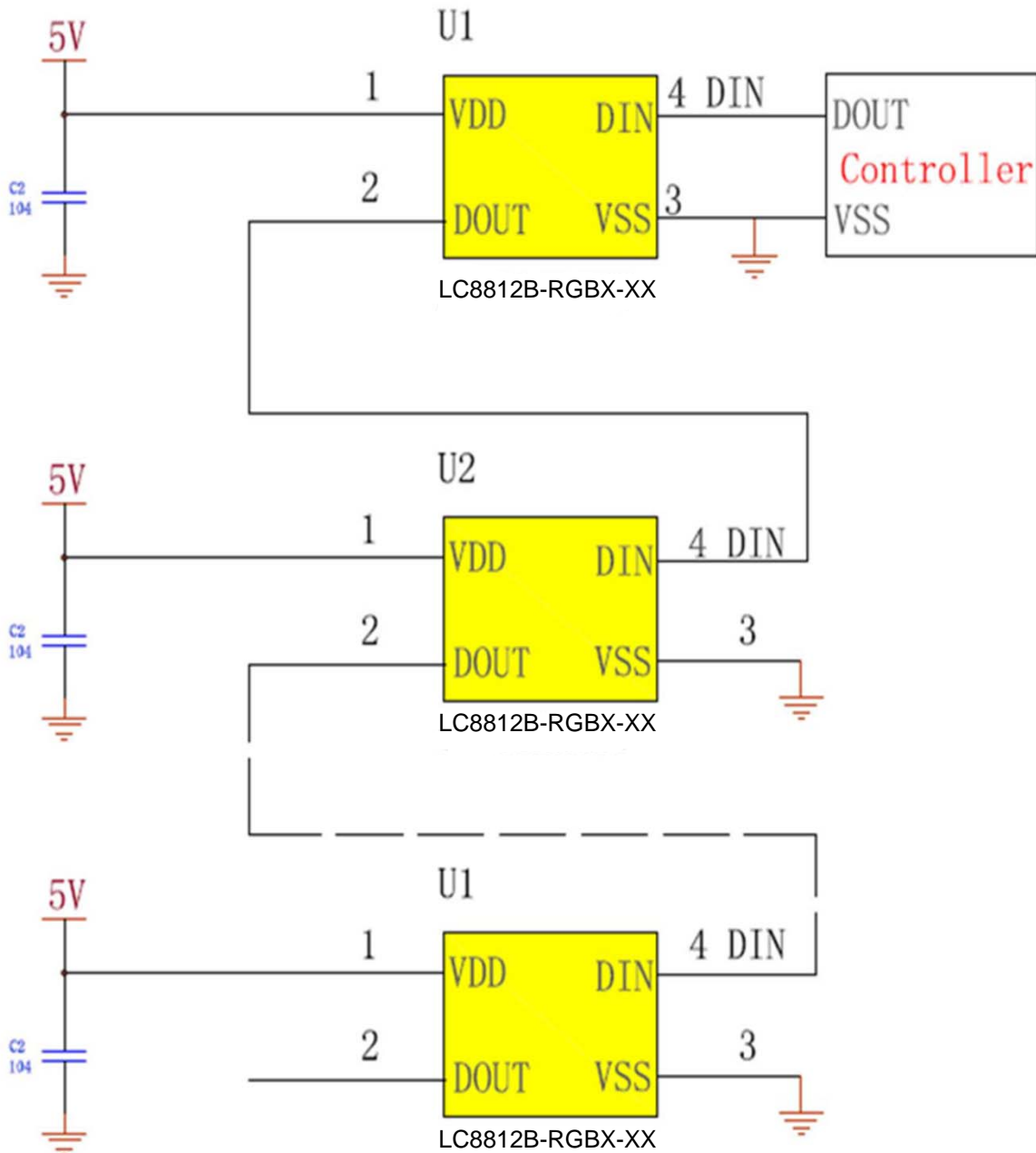

**15. White Color Temperature Ranks & CIE Color Rank (Refer to CIE 1931 chromaticity diagram)**

CIE chromaticity coordinates (ANSI Cool White)

CA	X1	Y1	X2	Y2	X3	Y3	X4	Y4
CA	0.305649	0.30617	0.29869	0.31022	0.30422	0.31765	0.31118	0.3136
CB	0.311181	0.3136	0.30422	0.31765	0.30975	0.32508	0.31671	0.32103
CC	0.316713	0.32103	0.30975	0.32508	0.31529	0.33252	0.32225	0.32847
CD	0.322245	0.32847	0.31529	0.33252	0.32082	0.33995	0.32778	0.3359
CE	0.327777	0.3359	0.32082	0.33995	0.32635	0.34738	0.33331	0.34333

ANSI Blue White Color bin structures

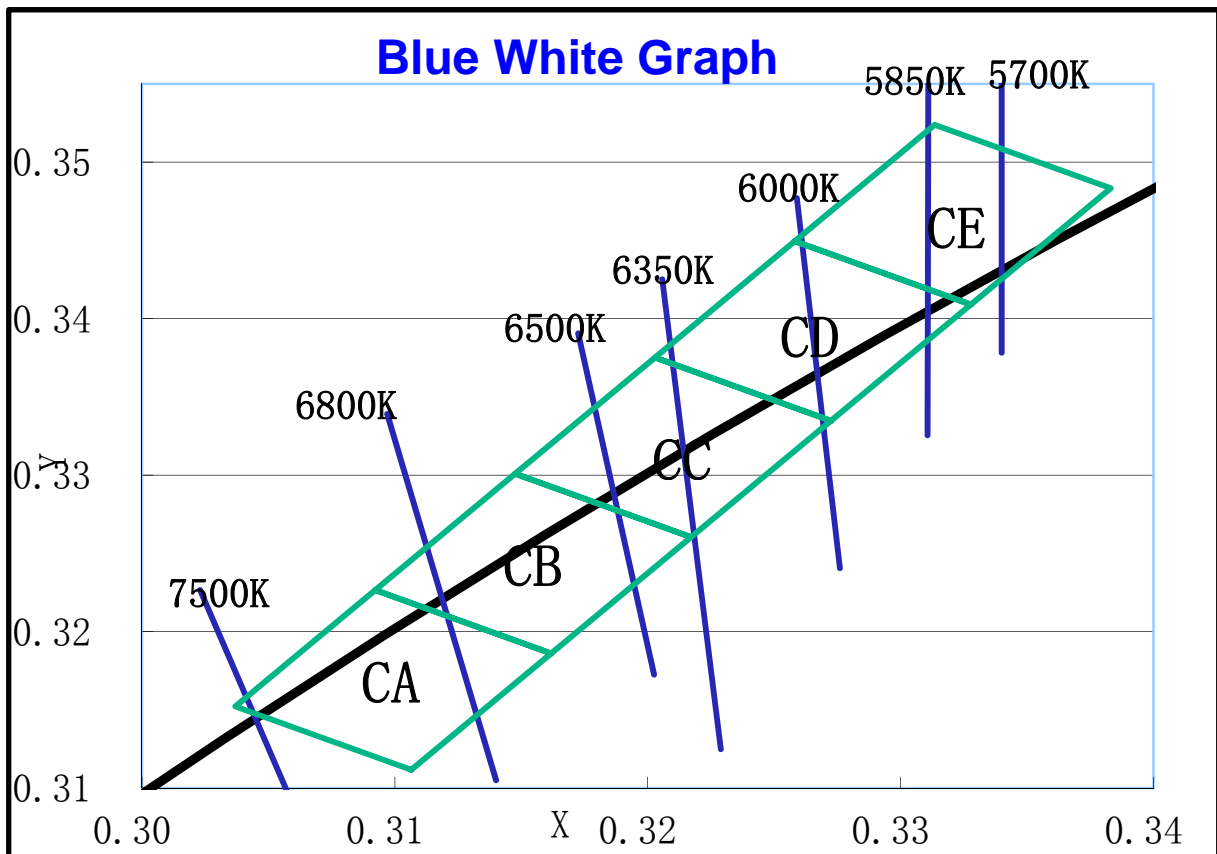

深圳市色彩光电有限公司  
Shenzhen LED Color Opto Electronic Co.,Ltd

CIE chromaticity coordinates (ANSI Natural white)

CA	X1	Y1	X2	Y2	X3	Y3	X4	Y4
NA	0.3662	0.3541	0.3578	0.3594	0.3623	0.3666	0.3707	0.3612
NB	0.3707	0.3612	0.3623	0.3666	0.3669	0.3737	0.3753	0.3683
NC	0.3753	0.3683	0.3669	0.3737	0.3714	0.3808	0.3798	0.3754
ND	0.3798	0.3754	0.3714	0.3808	0.3759	0.3879	0.3844	0.3825
NE	0.3844	0.3825	0.3759	0.3879	0.3805	0.3950	0.3889	0.3897

ANSI Natural White Color bin structures

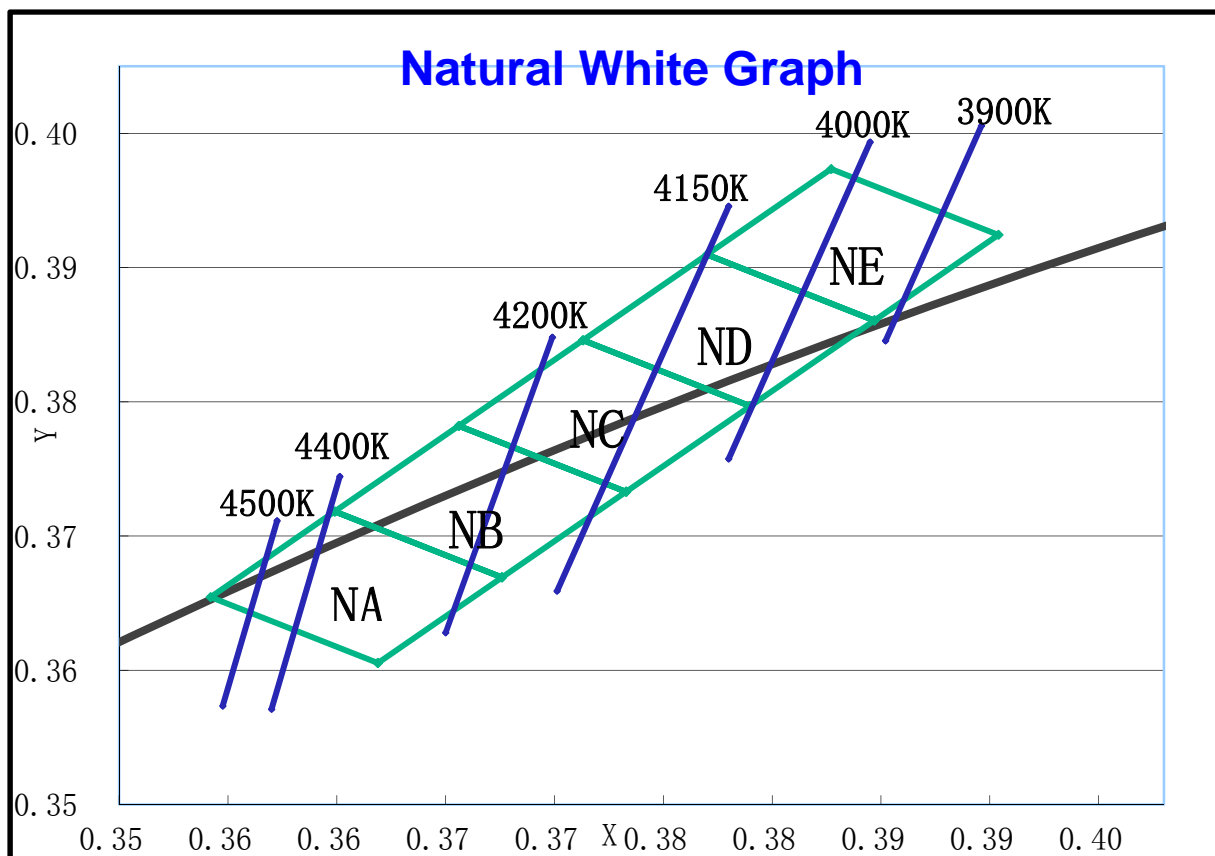



深圳市色彩光电有限公司  
Shenzhen LED Color Opto Electronic Co.,ltd

CIE chromaticity coordinates (ANSI Warm White)

CA	X1	Y1	X2	Y2	X3	Y3	X4	Y4
KA	0.427	0.386	0.420	0.393	0.426	0.399	0.433	0.392
KB	0.433	0.392	0.426	0.399	0.431	0.405	0.438	0.398
KC	0.438	0.398	0.431	0.405	0.437	0.411	0.444	0.404
KD	0.444	0.404	0.437	0.411	0.442	0.417	0.449	0.410
KE	0.449	0.410	0.442	0.417	0.448	0.423	0.455	0.416

ANSI Warm White Color bin structures

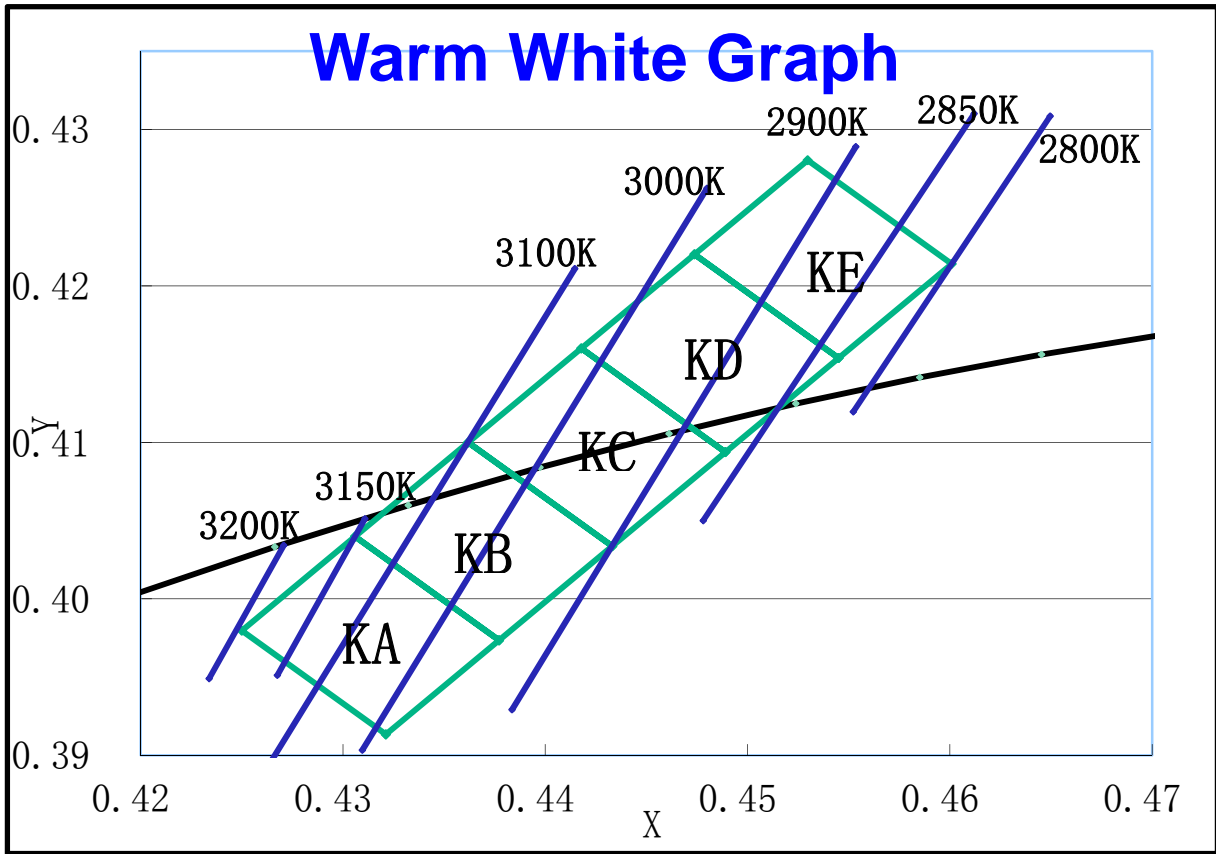

16. Standard LED Performance Graph:

Typical Relative Luminous Flux vs. Forward Current

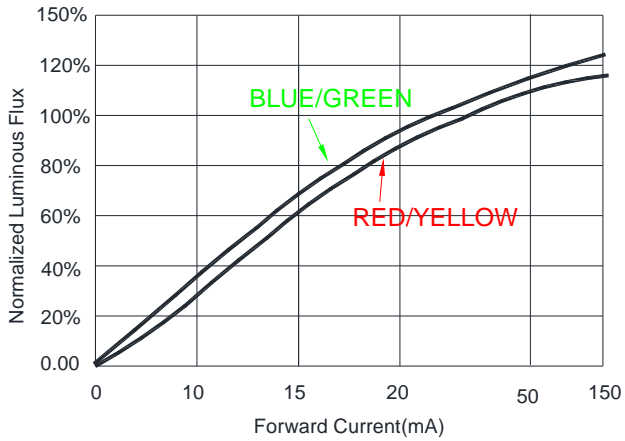

Forward Voltage vs. Forward Current

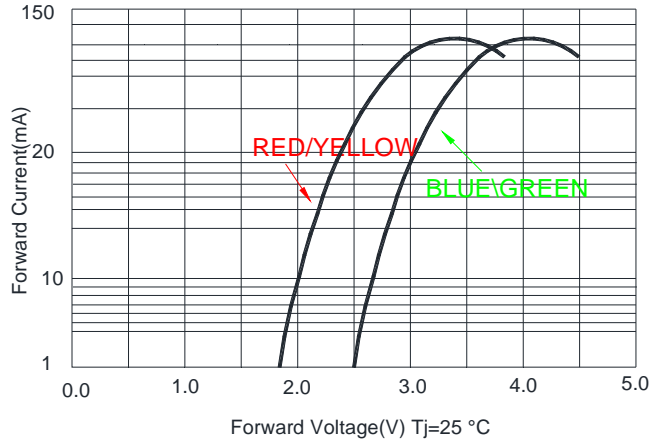

Thermal Pad Temperature vs. Relative Light Output

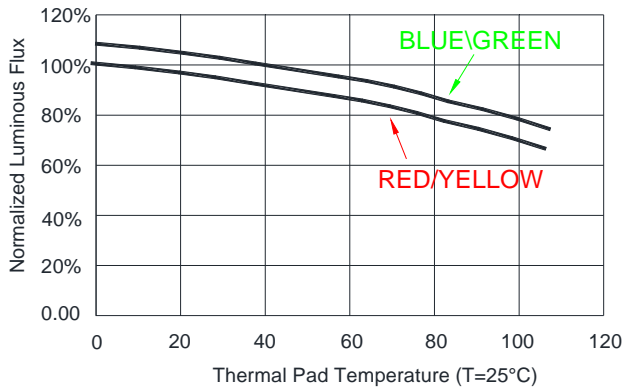

Wavelength Characteristics

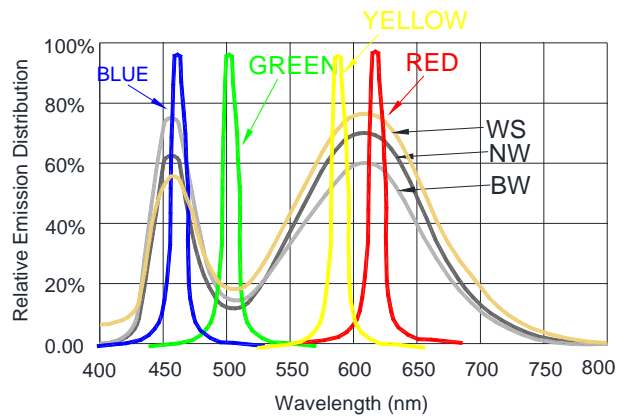

Thermal Pad Temperature vs. Forward Current

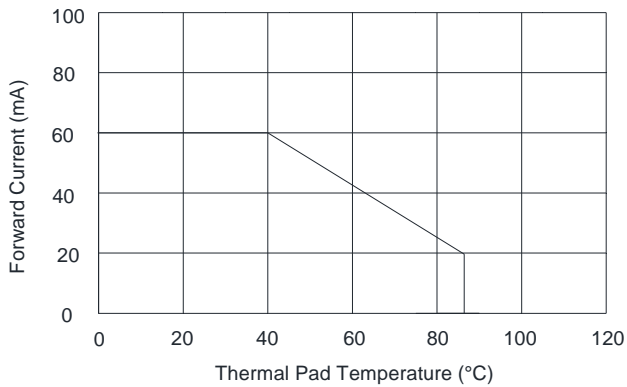

Typical Radiation Pattern 120°

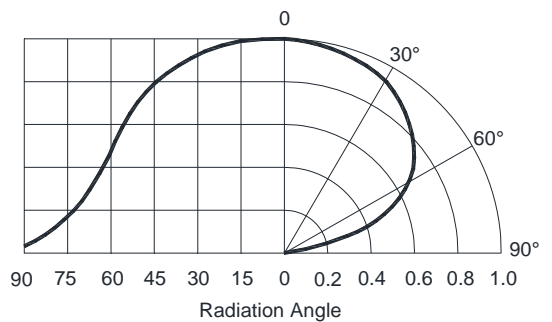

**17. Packaging Standard:**

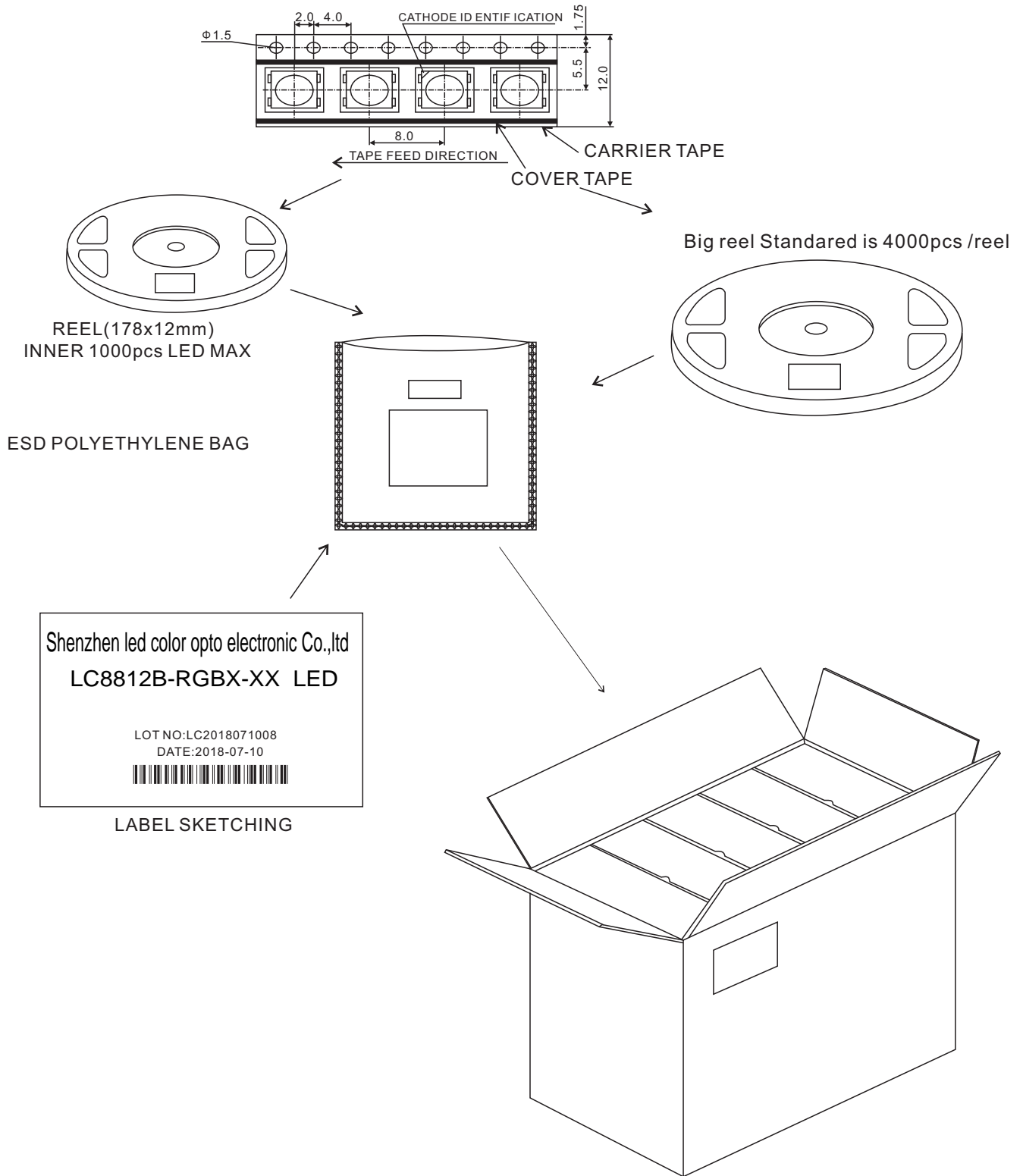

The reel pack is applied in SMD LED. The LEDs are packed in cardboard boxes after packaging in normal or anti-electrostatic bags. cardboard boxes will be used to protect the LEDs from mechanical shocks during transportation. The boxes are not water resistant and therefore must be kept away from water and moisture.

## **18. Attention**

### **18.1 Dust & Cleaning**

The LED use silicone glue to package the 5050 Surface, silicone surface can protect optical properties and improved anti-aging properties. However, silicone is a softer material and prone to attract dust. While a minimal amount of dust and debris on the LED will not cause significant reduction in illumination. We still need to avoid dust falling on the LED surface. After open the bags it must be used immediately.

When you use trichloroethylene or acetone to clean, sometimes the LED surface will dissolve.

Avoid using organic solvent, it is recommended that isopropyl be used as a solvent for cleaning the LEDs. When using other solvents, it should be confirmed beforehand whether the solvents will dissolve the package and the resin or not.

Do not clean the LEDs by the ultrasonic. When it is absolutely necessary, the influence as ultrasonic cleaning on the LEDs depends on factors such as ultrasonic power. Baking time and assembled condition.

Before cleaning, a pre-test should be done to confirm whether any damage to the LEDs will occur.

### **18.2 Dehumidification**

LED COLOR smart led are moisture sensitive components, In IPC/JEDEC J-STD-020 MSL Level is 6. **No Matter the Package bag is open or not ,The LED must do dehumidification in the oven for 24 hours at 70 degree before use and used within 4 hours, otherwise it need to be dehumidified again**

### **18.3 Reflow Soldering Characteristics**

In our Test, LED Color confirm those smart led are compatible with JEDEC J-STD-020C, Customers are required to follow the soldering temperature profile recommended by the solder paste manufacturer used.

Please note that this general guideline may not apply to all PCB design and reflow soldering equipment configurations.

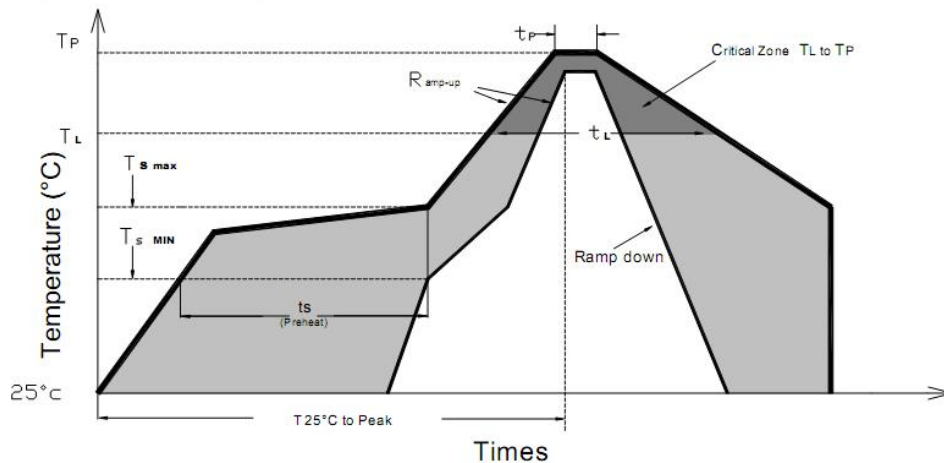

Profile Feature	Lead-Based Solder	Lead-Free Solder
Average Ramp-Up Rate (Ts max to Tp)	3 °C/second max.	
Preheat: Temperature Min (Ts min)	100°C	150°C
Preheat: Temperature Min (Ts max)	150°C	200°C
Preheat: Time (ts min to ts max)	60-120 seconds	60-180 seconds
Time Maintained Above: Temperature (TL)	183 °C	217 °C
Time Maintained Above: Time (tL)	60-150 seconds	60-150 seconds
Peak/Classification Temperature (TP)	215 °C	238 °C
Time Within 5°C of Actual Peak Temperature (tp)	<10 seconds	<10 seconds
Ramp-Down Rate	6 °C/second max	6 °C/second max
Time 25 °C to Peak Temperature	<6 minutes max	<6 minutes max

Note: All temperatures refer to topside of the package, measured on the package body surface.

#### 18.4. Anti-static and surge protection for IC devices

Static electricity and surges can damage the LED products of IC devices, so appropriate protective measures must be taken;

The signal input and output ports of IC devices must be connected in series with protective resistors to prevent product failure due to surge or electrostatic shock ports;

In order to protect the LED products of IC devices, whenever you encounter LEDs, wear anti-static straps, anti-static straps and anti-static gloves.

All devices and equipment must be grounded

It is recommended that each product be tested before shipment for relevant electrical tests to select defective products due to static electricity.

In the design of the circuit, consideration should be given to eliminating the surge to the LED

### 18.5 Other requirements

SMT nozzle requirements: (red circle refers to the inside diameter of the nozzle)

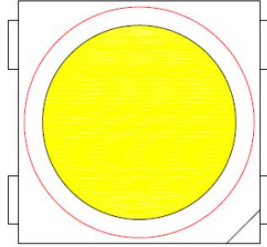

OK (the inside diameter of the nozzle is larger than the light-emitting area of the lamp)

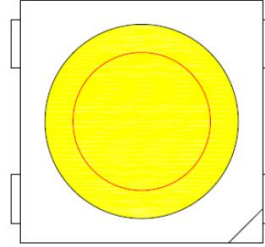

NG (the inside diameter of the nozzle is smaller than the lighting area of the lamp)

Pressing the colloid surface will affect the reliability of LED because the LED is advanced silicone-gel. And therefore precautions should be taken to avoid the strong pressure on the component. It's proper to make the LED be used in safe condition when using a suction nozzle. Silicon packing with soft and elastic, it greatly reduces thermal stresses and unable to bear external mechanical forces. Therefore, preventive measures should be taken in process of manually handling.

① Clip the LED from its side. Neither directly touch the gel surface with the hand or sharp instrument, it may damage its internal circuit.

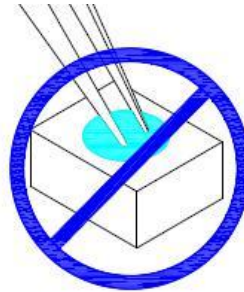

② Not to be double stacked, it may damage its internal circuit.

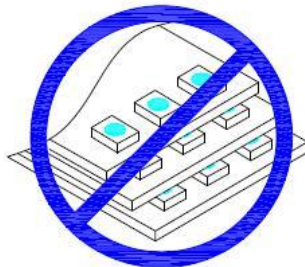

- ③ Can not be stored in or applied in the acidic sites of PH<7.



**Modify Records**

<b>Item NO.</b>	<b>Rev. No.</b>	<b>Modify Content Summary</b>	<b>Signature</b>	<b>Date</b>
LC8812B-RGBX-XX	03	Initial Document	Andy Zhu	2018-07-09