

# LC8822-2020

◆Outline (L\* W\*H): 2.0\*2.0\*0.75mm

◆Good thermal dissipation & optical uniformity

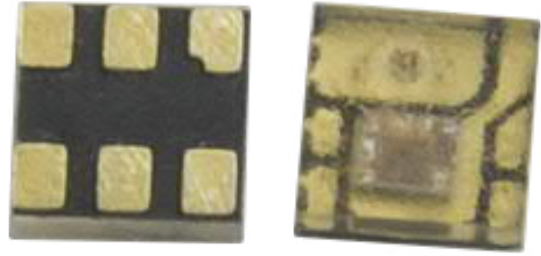

## Table of Contents

Product Code Method-----	2
Maximum Rating-----	2
Typical Product Characteristics-----	3
Range of Bins-----	4
Color Coordinate Comparison-----	4
Electrical Characteristics -----	5
Switching Characteristics -----	5
Data transfer time -----	5
Dimensions -----	6
PIN Configuration -----	7
Reflow Profile -----	8
Test Circuit and Handling Precautions -----	9
Packing-----	11
Precautions-----	12
Test Items and Results of Reliability-----	13

## Features

- RoHS2.0 Compliant
- Packaged in 12mm tape on 7" diameter reels
- EIA STD package
- Compatible with automatic placement equipment and infrared reflow solder process
- Preconditioning: accelerate to JEDEC level 3
- Serial data transmission signal by (DATA CLK) two line
- ESD level 2kV(HBM)

## Applications

- Telecommunication, office automation, home appliances, industrial equipment
- Status indicator
- Signal and symbol luminaire
- Front panel backlighting
- Full-color strip.
- Indoor decorative lighting / curtain display

深圳市色彩光电有限公司  
Shenzhen LED Color Opto Electronic Co.,ltd

---

■ **Product Code Method**

---

LC8822-2020

①            ②            ③            ④            ⑤

①	②	③	④	⑤
Brand Name	Model Number	Lead Frame Size	Gray Scale	Pin Number
Company Prefix	Model: LC8822-2020	2020: 2.0*2.0mm	256 gray scales	6 Pins type led

■ **Maximum Rating(Ta=25°C)**

---

Parameter	Symbol	Rating	Unit
IC Power Supply Voltage	VCC	+4.5~+5.5	V
LED voltage	Vled	3-7.5	V
Rate of data signal	F <sub>CLK</sub>	20	MHZ
The max led output Current	I <sub>OMAX</sub>	18	mA
Channel current deviation	D <sub>IO</sub>	Channel<3%,chip<5%	%
Power dissipation;	P <sub>D</sub>	<350	mW
Soldering Temperature <sup>*1</sup>	T <sub>SD</sub>	260	°C
Operating Temperature Range	-40°C to +85°C		
Storage Temperature Range	-40°C to +105°C		

Notes 1: The maximum of soldering time is 5 seconds in T<sub>SD</sub>

■ Typical Product Characteristics(Ta=25°C)

Characteristics	Symbol	Min.	Typ.	Max.	Unit	Test condition	
Forward Voltage	$V_F$	4.5		5.5	V	$I_F=18mA$	
Luminous Intensity	Iv	R	-	230	-	mcd	$I_F=18mA$
		G	-	320	-		
		B	-	80	-		
		W	270	530	-		
Dominant Wavelength	$\lambda_d$	R	615	-	630	nm	$I_F=18mA$
		G	520	-	530		
		B	460	-	475		
Color Coordinate	x		0.2257			$I_F=18mA$	
	y		0.2234				
View Angle	$2\theta_{1/2}$	-	120	-	deg	$I_F=18mA$	

■ Electrical Characteristics (Ta=25°C)

Characteristics	Symbol	Condition	Min.	Typ.	Max.	Unit
Supply voltage	$V_{CC}$			5.0	5.5	V
Input voltage	$V_{IN}$		-0.4		5	V
Rate of data signal	FCLK		0	15	-	MHZ
Input voltage level	$V_{IH}$	D <sub>IN</sub> , SET	0.7 $V_{CC}$	-	-	V
	$V_{IL}$	D <sub>IN</sub> , SET	-	-	0.3 $V_{CC}$	V
The clock high level width	T <sub>CLKH</sub>		30	-	-	ns
The clock low level width	T <sub>CLKL</sub>		30	-	-	ns
Data set up time	T <sub>SETUP</sub>		10	-	-	ns
Data hold time	T <sub>HOLD</sub>		5	-	-	ns

■ Range of Bins

1) Luminous Intensity-White ( $I_F = 18\text{mA}$ )

Bin Code	Min. IV (mcd)	Max. IV (mcd)
10	270	350
11	350	460
12	460	600
13	600	780
14	780	1000

■ Color Coordinate Comparison-White

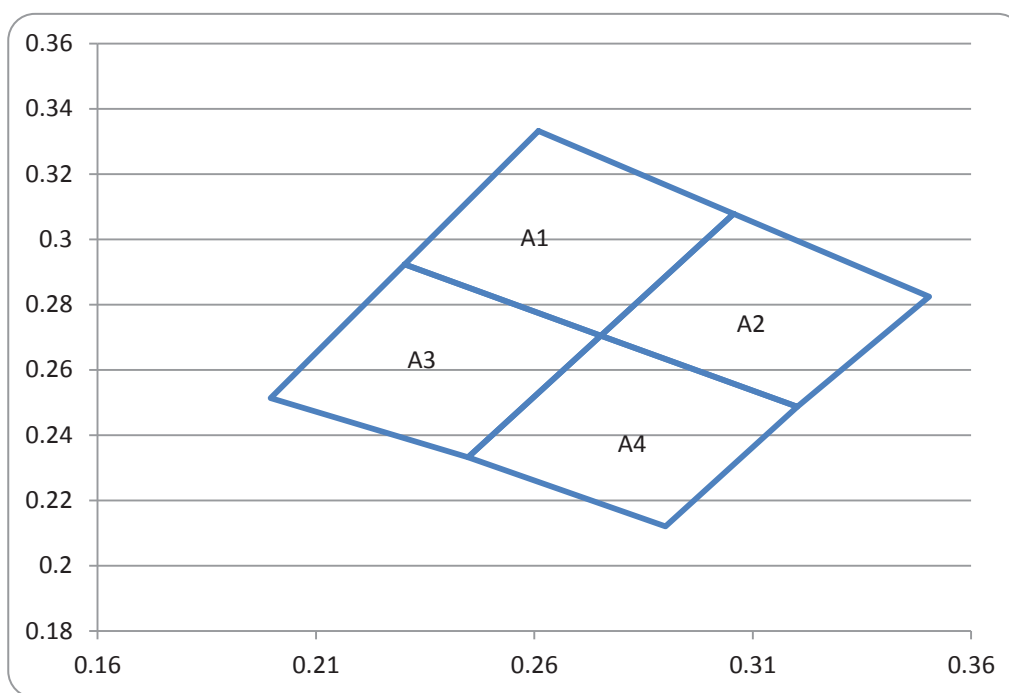

Color Rank

BIN Code	X	Y	X	Y	X	Y	X	Y
A1	0.2609	0.3332	0.3056	0.3078	0.2752	0.2705	0.2303	0.2923
A2	0.3056	0.3078	0.3504	0.2824	0.3202	0.2487	0.2752	0.2705
A3	0.2303	0.2923	0.2752	0.2705	0.2448	0.2332	0.1996	0.2513
A4	0.2752	0.2705	0.3202	0.2487	0.29	0.212	0.2448	0.2332

■ **Switching Characteristics (Ta=25°C)**

Characteristics	Symbol	Condition	Min.	Typ.	Max.	Unit
Transfer time	T <sub>THH</sub>	CL=30pF,RL=1K Ω	-	-	15	ns
	T <sub>THL</sub>		-	-	15	ns
Signal delay time	T <sub>pd</sub>	CL=30pF,RL=1K Ω	-	-	12	ns
	T <sub>co</sub>		-	-	12	ns
Signal rise and fall time	T <sub>R</sub>	V <sub>cc</sub> =5V	-	-	500	ns
	T <sub>F</sub>		-	-	400	ns
The output minimum PWM opening width	T <sub>ONMIN</sub>	I <sub>OUT</sub> = 18mA	200	-	-	ns
The output signal maximum opening and closing time	T <sub>ON</sub>	I <sub>OUT</sub> = 18mA	-	--	80	ns
	T <sub>Off</sub>		-	-	80	ns

■ **Communication protocol and timing (Ta=25°C)**

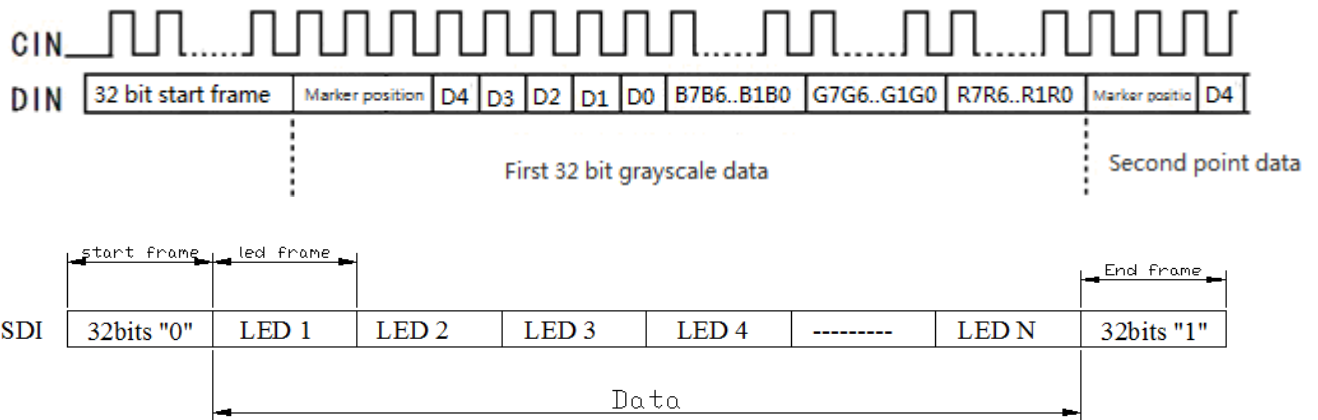

1. The first 32 bit "0" is the starting frame, and the CIN is on the rise time, and the timing DIN is preceded by CIN
2. It is marked as "1"
3. D4 D3 D2 D1 and D0 are 32 level brightness adjustment, D4 is the highest
4. The gray level data to high, the sequence is B/G/R

■ Dimensions

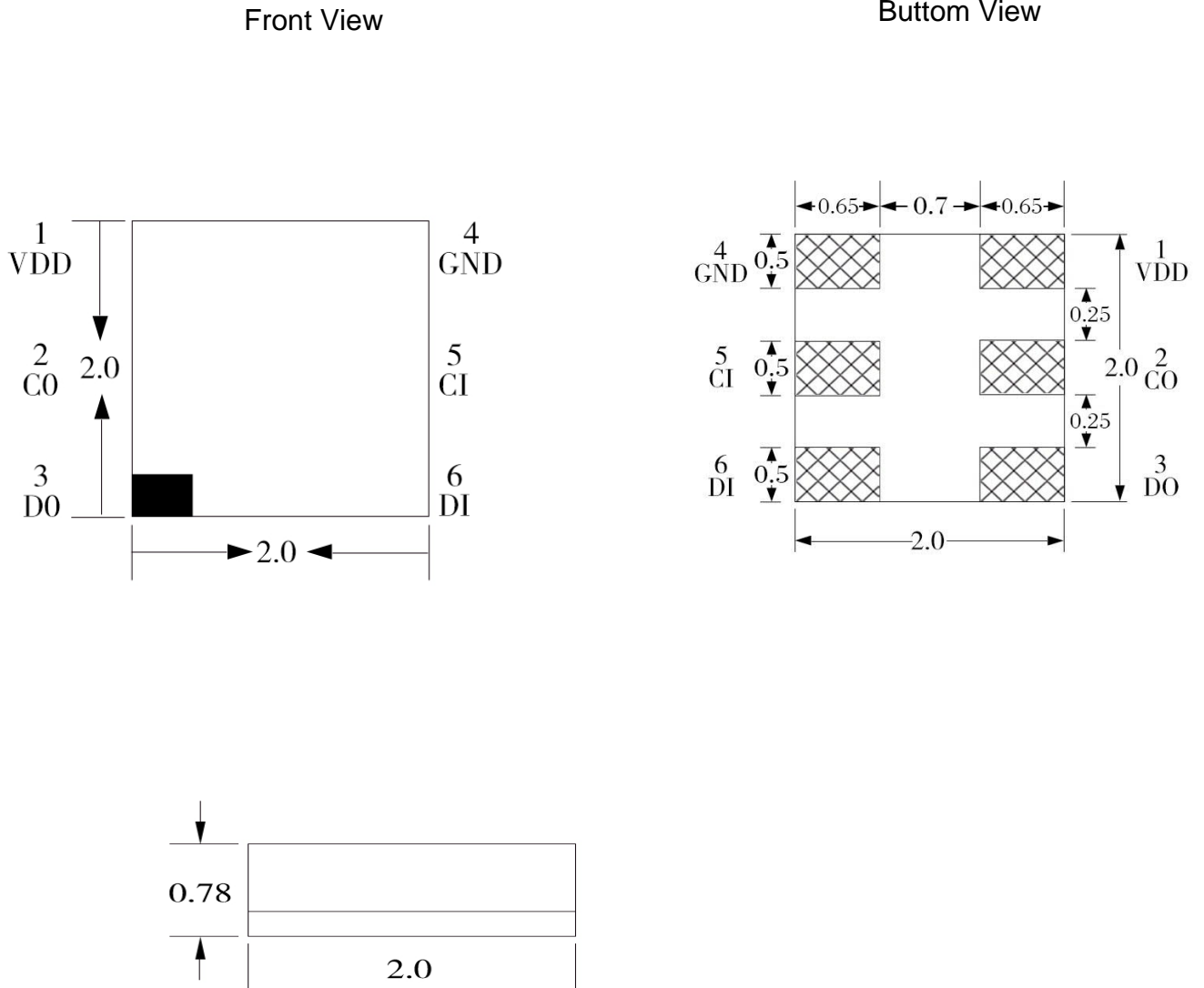

- § All dimensions are in millimeters.
- § Tolerance is  $\pm 0.1$ mm unless other specified
- § Specifications are subject to change without notice

■ PIN Configuration

---

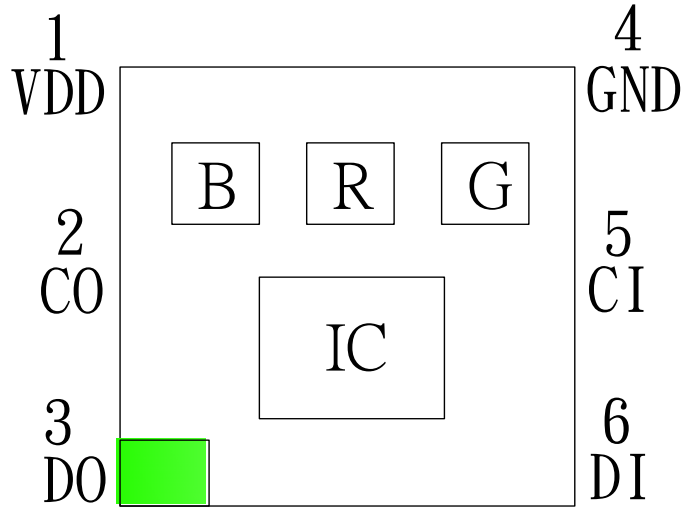

No.	Symbol	Function description
1	VDD	Supply Voltage
2	CO	Clock output
3	DO	Data output
4	GND	Ground
5	CI	Clock input
6	DI	Data input

■ **Reflow Profile**

1. **I<sub>R</sub> reflow soldering Profile for Lead Free solder**

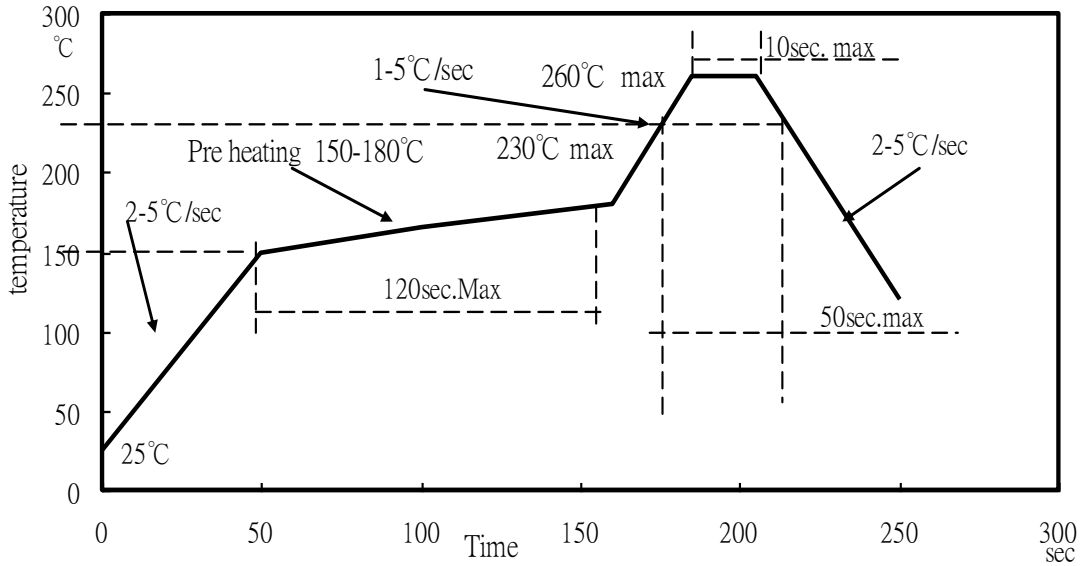

**Notes:**

1. We recommend the reflow temperature at 240°C (±5°C), and the maximum soldering temperature should be limited to 260°C.
2. Don't cause stress to the silicone resin while it is exposed to high temperature.
3. Number of reflow process shall not be more than 1 time.

■ **Test Circuit and Precautions for Use**

1. **Typical application circuit**

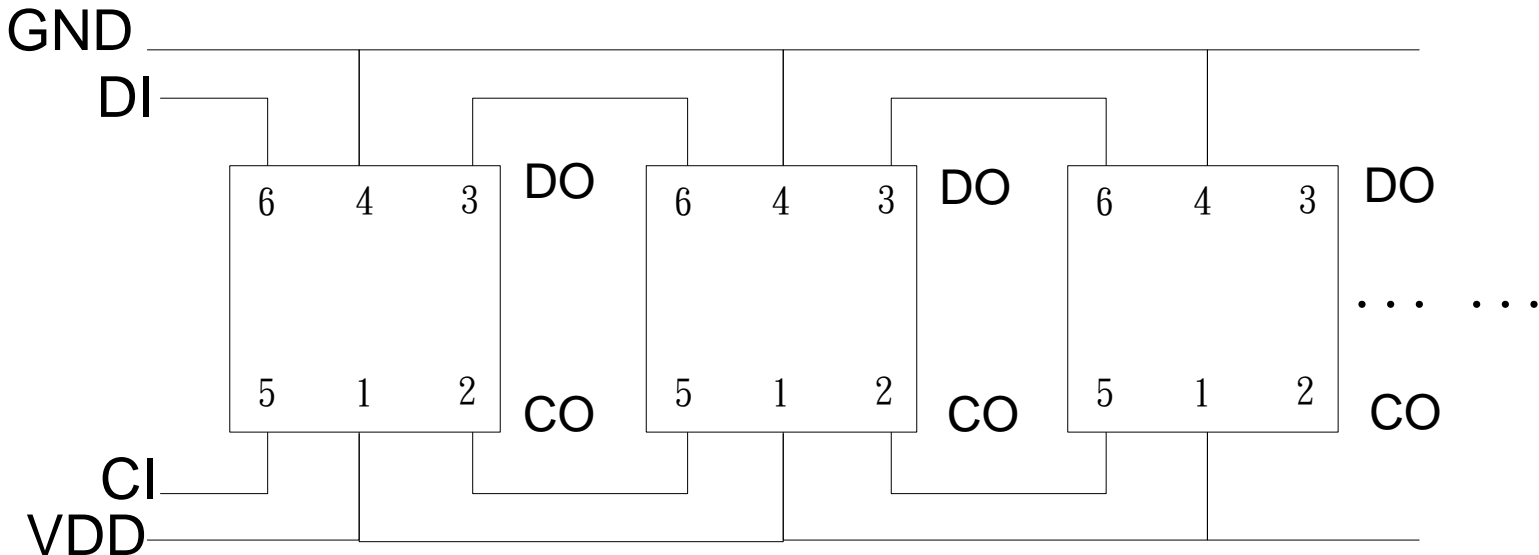



## 2. Precautions for Use

### 2.1. Over-current-proof

Customer must apply resistors for protection; otherwise slight voltage shift will cause big current change (Burn-out will happen).

### 2.2. Storage

1). To store the products is recommended with following conditions:

Humidity: 60% R.H. Max.

Temperature: 5°C~30°C (41°F~86°F)

2). Shelf life in sealed bag: 12 month at <5°C~30°C and <60% R.H. after the package is Opened, the products should be used within 1 week or they should be keeping to stored at  $\leq 20\%$ R.H. with zip-lock sealed.

### 2.3. Baking

If the package has been opened for more than 1 week, it is recommended to bake the products with the following instruction:

1). 60±3°C X 6hrs and <5%RH, for reel

2). 125±3°C X 2hrs, for single LED

It shall be normal to see slight color fading of carrier (light yellow) after baking in process

■ Packing

● Feeding Direction

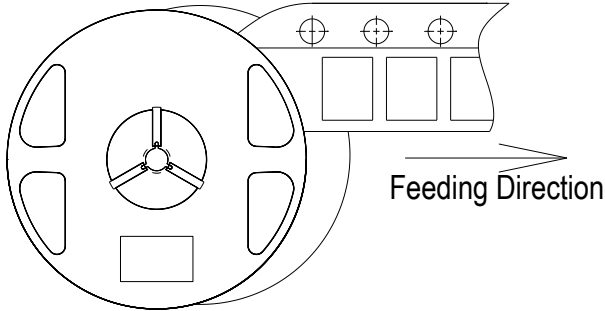

● Dimensions of Reel (Unit: mm)

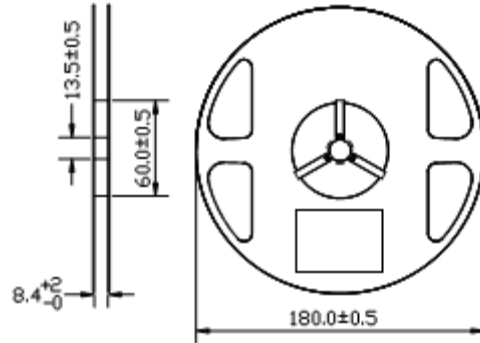

● Dimensions of Tape (Unit: mm)

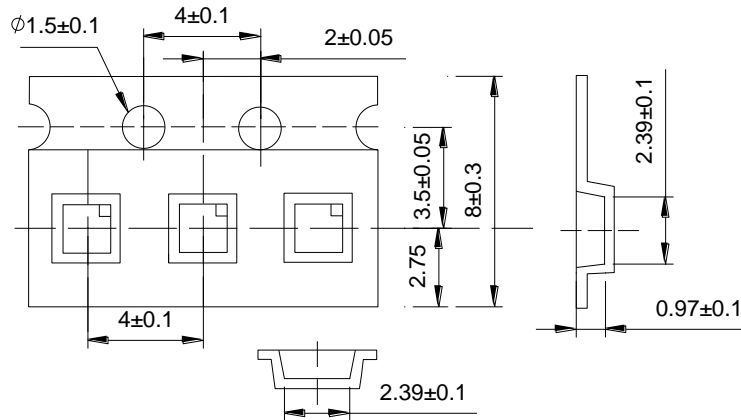

● Arrangement of Tape

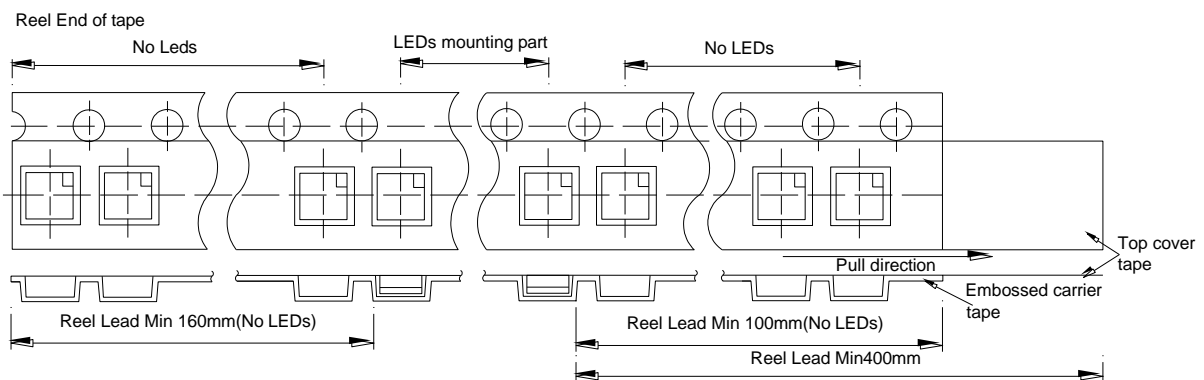

Notes:

1. Empty component pockets are sealed with top cover tape;
2. The max loss number of SMD is 2pcs;
3. The cathode is oriented towards the tape sprocket hole in accordance with ANSI/EIA RS-481 specifications;
4. 4000pcs per reel

## ■ Packing

### ● Packaging Specifications

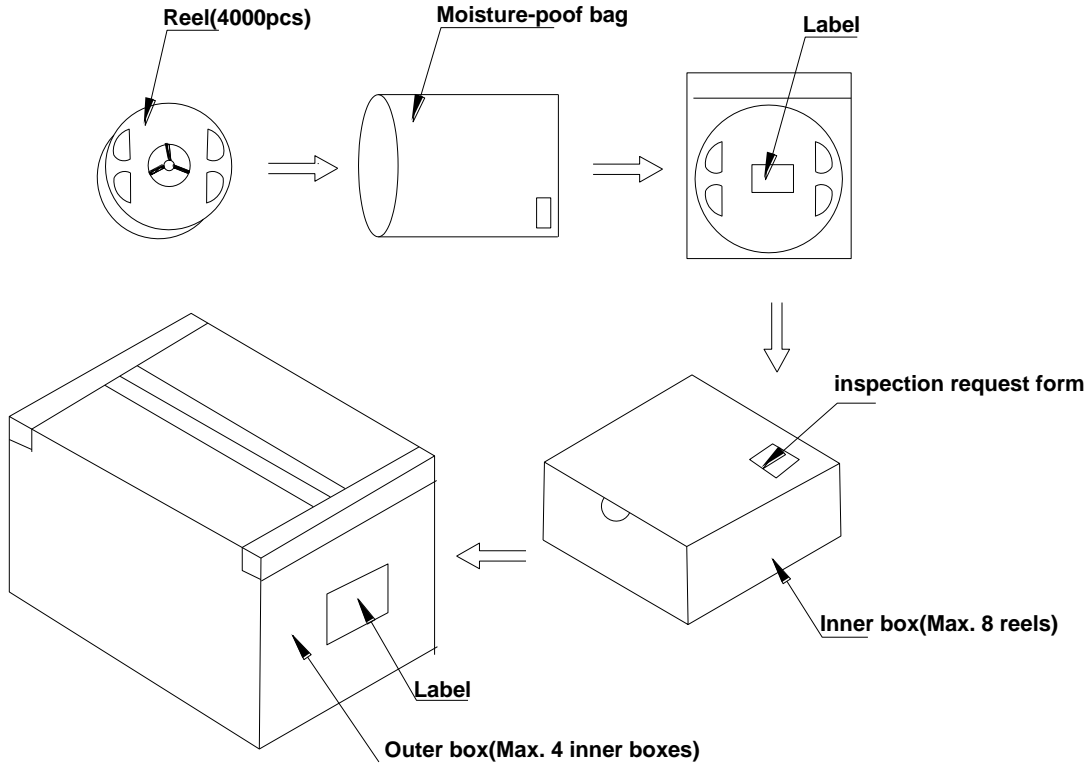

#### Notes:

Reeled product (max.4000) is packed in a sealed moisture-proof bag. Seven bags are packed in an inner box (size: about 260 X 230 X 100 mm) and four inner boxes are in an outer box (size: about 480 X 275 X 215mm). On the label of moisture-proof bag, there should be the information of Part No., Lot No. and quantity number; also the total quantity number should be on inspection request form on outer box.

## ■ Precautions

---

### 1. Abnormal situation caused by improper setting of collet

To choose the right collet is the key issue in improving the product's quality. LED is different from other electronic components, which is not only about electrical output but also for optical output. This characteristic made LED more fragile in the process of SMT. If the collet's lowering down height is not well set, it will bring damage to the gold wire at the time of collet's picking up and loading which will cause the LED fail to light up, light up now and then or other quality problems

### 2. How to choose the collet

During SMT, please choose the collet that has larger outer diameter than the lighting area of lens, in case that improper position of collet will damage the gold wire inside the LED. Different collets fit for different products, please refer to the following pictures cross out

**Outer diameter of collet should be larger than the lighting area**

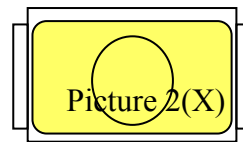
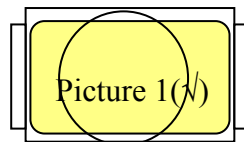

### 3. Other points for attention

A. No pressure should be exerted to the epoxy shell of the SMD under high temperature.

B. Do not scratch or wipe the lens since the lens and gold wire inside are rather fragile and cross out easy to break.

C. LED should be used as soon as possible when being taken out of the original package, and should be stored in anti-moisture and anti-ESD package.

### 4. This usage and handling instruction is only for your reference.

深圳市色彩光电有限公司  
Shenzhen LED Color Opto Electronic Co.,Ltd

■ Test Items and Results of Reliability

Test Item	Test Conditions	Duration/ Cycle	Ac/Re	Number of Damage	Reference
Normal Temperature Life	Ta=23°C(±5°C) I <sub>F</sub> =18mA	1008 hrs	0/1	0/22	JESD22 A-108
High Temperature Life	Ta=85°C(±5°C) I <sub>F</sub> =18mA	1008 hrs	0/1	0/22	JESD22 A-108
High Humidity Heat Life	Ta=85°C(±5°C) RH=85% I <sub>F</sub> =18mA	1008 hrs	0/1	0/22	JESD22 A-108
Thermal shock	-45°C/30min~105°C /30min (±5°C)	1008 hrs	0/1	0/22	JESD22 A-104
Electrostatic Discharge (ESD) Test	According to the SPEC	3 cycles	0/1	0/22	AEC Q101-001
Low Temperature Storage	T <sub>a</sub> =-40°C	1008 hrs	0/1	0/22	JESD22-A103D
High Temperature Storage	T <sub>a</sub> =125°C	1008 hrs	0/1	0/22	JESD22-A103D

*Criteria for Judging				
Item	Symbol	Condition	Criteria for Judgment of Pass	
			Min	Max
Forward Voltage	V <sub>F</sub>	I <sub>F</sub> =18mA	-	USL* <sup>1</sup> ×1.1
Reverse Current	I <sub>R</sub>	V <sub>R</sub> = 5V	-	10μA
Luminous Intensity	I <sub>v</sub>	I <sub>F</sub> =18mA	LSL* <sup>2</sup> ×0.7	-

[Note] USL\*<sup>1</sup>: Upper Specification Level

LSL\*<sup>2</sup>: Lower Specification Level